



Project _____
 AIA # _____ SIS # _____
 Item # _____ Quantity _____ C.S.I. Section 114000



MG2032 Mixer-Grinder



MODELS

- MG2032** Mixer-Grinder, hopper capacity 200 pounds

STANDARD FEATURES

- + Exclusive WEDGE cylinder ensures full rate feeding for the entire batch
- + 7.5 HP grind motor, 1 HP mix motor
- + 8 foot cord and plug power connection
- + Pneumatic foot control
- + Hand removable and interchangeable seals
- + Counterbalanced lid
- + Double-sealed push button control panel with condensate heater
- + Easy access hopper interior and exterior surfaces
- + 200 pound hopper capacity
- + Side feed option for tandem grinding (right side only)
- + Convenient load and discharge height
- + Double-wall construction for added sanitation

OPTIONAL FEATURES & ACCESSORIES

- #32 Stay-Sharp knife and plates
- Split level grinding table
- X-frame rolling lug cart
- Side board
- #32 end ring adapter for tandem
- Bulker adapter for Hollymatic

SPECIFIER STATEMENT

Specified unit will be an NSF rated, Hobart mixer-grinder with a 200 pound hopper capacity. Unit has separate mix and grind motor; mix motor is 1 HP and grind motor is 7.5 HP. Features include an exclusive WEDGE cylinder that ensures full rate feeding, a pneumatic foot control, hand removable and interchangeable seals, and counterbalanced lid. Double wall construction and double-sealed push button control panel with condensate heater.

MG2032 MIXER-GRINDER

Approved by _____ Date _____ Approved by _____ Date _____



SOLUTIONS/BENEFITS

PERFORMANCE

Separate Grind and Mix Motors

- + 7.5 HP grind motor, 1 HP mix motor

Stay-Sharp Knife and Plates

- + Made from an alloy steel that holds its edge longer than standard carbon steel

Stainless Steel Finish

- + Easy to clean and exceptionally durable

EASE OF USE

Pneumatic Foot Control

- + Makes operation easier and more ergonomic

Large Hopper Capacity

- + 150 pound hopper capacity for large loads

Easy-Access Hopper Interior and Exterior Surfaces

- + Makes loading and unloading faster and easier

SANITATION & CLEANING

Removable Parts

- + The mixing arm, conveyor screw, cylinder, conveyor screw drive seal and mix arm seal are all removable for easy cleaning

Stainless Steel Finish

- + Easy to clean and exceptionally durable

Easy-Access Hopper Interior and Exterior Surfaces

- + Makes cleaning interior and exterior easier for the operator

SPECIFICATIONS:

Motor: 7.5 HP grind motor, 1 HP mix motor.

Electrical: Available in 208/60/3 and 480/60/3.

Switch: Electrical controls consist of front-mounted water resistant switches, magnetic contactors, dual-motor overload protection and foot switch operation capability.

Grinding End: The mixer-grinder is equipped with a “wedge cylinder” grinding end. This grinding end is sized for #32 knives and plates (not included but optionally available).

Capacity: 200 pound hopper capacity.

Finish: Glass bead finished stainless steel hopper, stainless steel panels to enclose the base assembly and motors.

Optional Equipment: Hopper side feed inlet (right side only)

Special Equipment: When MG2032 is used with tandem side feed, a #32 adapter ring is required in order to connect the machine to another mixer grinder.

Warranty: 1-year parts, labor, and travel during normal working hours within the USA.

Cord and Plug: 8 foot cord and plug power connection.

Plugs and Receptacles:

Machine Voltages	
Service Current Requirement if Plug Connected	208/60/3
	460/60/3
	20, 30 Amp.
Terminal Designation of Plug	3 Pole 4 Wire Grounding
NEMA Plug Configuration	L15-30P, L16-20P
Plug Configuration	
Molded Plug on Cord	No
Plug - Straight/Angle	Straight
NEMA Receptacle or Connector Configuration	L16-20P

DETAILS AND DIMENSIONS

Voltage	NEMA Configuration		
	Plug	Connector	Receptacle
208/60/3	L15-30P	L15-30R	L15-30R
480/60/3	L16-20P	L16-20R	L16-20R

WARNING: Electrical and grounding connections must comply with the applicable portions of the National Electrical Code and/or other local electrical codes.

POWER CORD SUPPLIED AS STANDARD (LENGTH APPROX. 8 FT) REQUIRES A WATER TIGHT RECEPTACLE OR CONNECTOR (SELECT BY VOLTAGE-SEE CHART). RECEPTACLE SHALL BE INSTALLED IN A TYPE FD CONDUIT BOX.

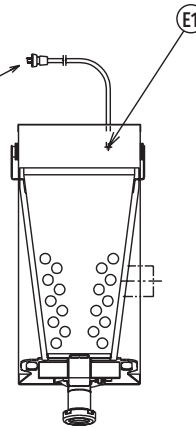

LEGEND

Electrical Connections	
E1	Electrical connection

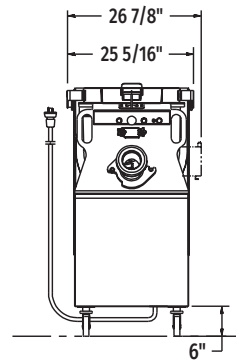
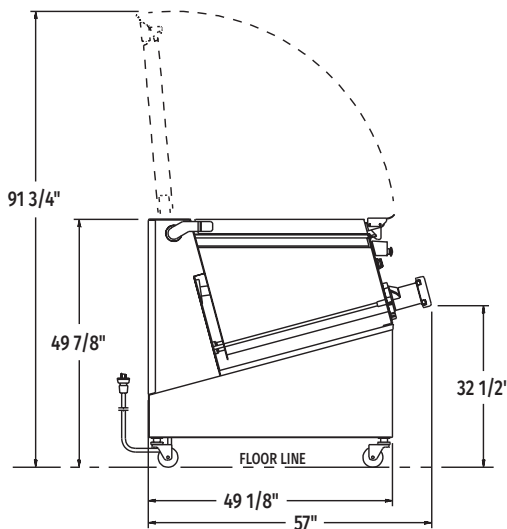

ADJUSTABLE CASTERS MAY ADD AN ADDITIONAL 2-1/2" TO ALL HEIGHT DIMENSIONS (SEE NOTE 1)

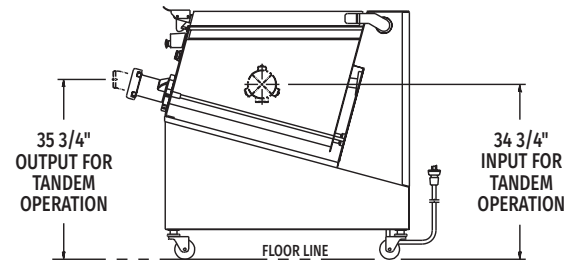

SPECIFICATIONS

Grind Motor (H.P.)	7-1/2
Mix Motor (H.P.)	1
Rated Amps @ 208/60/3	30.0
480/60/3	15.0

NOTES: May be supplied with casterless feet. Casterless feet to adjust an additional 2".