



ELXC SERIES

ITEM NO. _____

MODEL "ELXC-SPC-SO"

HIGH EFFICIENCY EXTRACTOR VENTILATOR
WITH CLEAN-IN-PLACE TECHNOLOGY,
ULTRAVIOLET IRRADIATION, ODOR CONTROL
& ELECTROSTATIC PRECIPITATOR FOR SMOKE CONTROL

GENERAL SPECIFICATIONS AND DESCRIPTION

Furnish Gaylord Ventilator Eliminator Model "ELXC-SPC-SO _____"
as shown on plans and in accordance with the following specifications:

HIGH EFFICIENCY EXTRACTION: Each ventilator shall contain "XGS" High Efficiency Extractors utilizing the "capture and drain" principle. Extractor efficiencies shall be determined using ASTM F2519-2005 testing procedures. The "capture and drain" principle shall prevent water from entering the plenum and duct areas during "FAN ON" wash cycles, thus providing 24/7 operators the full effect of Clean-In-Place technology. Each ventilator shall contain secondary filters to enhance performance and optimize efficiency positioned between the XGS High Efficiency Filters and UV Lamps.

HOOD CONTROLS: Each ventilator shall be IMC compliant and incorporates canopy mounted RTD's positioned strategically across the length of the hood.

CAPTURE AND CONTAINMENT: Each ventilator shall achieve capture and containment using the lowest possible airflow rates and may include an integrated capture wall.

CLEAN-IN-PLACE WASH TECHNOLOGY: Each ventilator shall include two full length stainless steel wash manifolds with brass nozzles; one to wash the inlet face and internal passages of the extractors during "FAN ON" mode and one to wash the plenum chamber during the "FAN OFF" mode as programmed by the Gaylord Command Center. Each wash manifold on each ventilator section shall operate independently so each wash cycle may be programmed at different frequencies and different durations to reduce water and detergent usage and optimize cleaning efficacy according to load and demand. Each ventilator section shall drain to sloping gutters with 2" outlets.

ULTRAVIOLET SYSTEM: The ventilator shall include ultraviolet lamps mounted in modules located in the plenum section(s). The UV module shall be on a slide track for easy removal. Access to the UV modules shall be through keyed and hinged access doors. Two redundant pressure switches shall be provided to monitor the airflow and prevent operation of the UV lamps if the access doors are open, or if any "XGS" Extractor is removed, or if the airflow is inadequate. Mounted on the canopy roof of each ventilator section shall be status lights to monitor "UVi System On", "UVi Lamp Failure", "UVi System Stand By", and cell operational status. The Gaylord Command Center shall display text that duplicates the ventilator mounted status lights. UV system shall incorporate a high temperature shut down set to trigger upon detection of excessive temperatures.

COLD WATER MIST: An optional cold water mist manifold may be installed at the hood inlet for heavy or extra heavy-duty applications.

ODOR NEUTRALIZER: The Ventilator shall contain spray nozzles supplied with water from the building cold water supply system and supplied with an odor catalyst that works in conjunction with the UV Lamps. The volume of odor catalyst will vary based on the system recognizing and adapting to the cooking activity and environment.

SMOKE CONTROL SECTION: The smoke control section shall contain one electrostatic precipitator (ESP) cell to remove smoke particles from the air stream to industry standards or to a level of 95% efficiency in accordance with ASHRAE std 52.2 resulting in no higher than 20% opacity

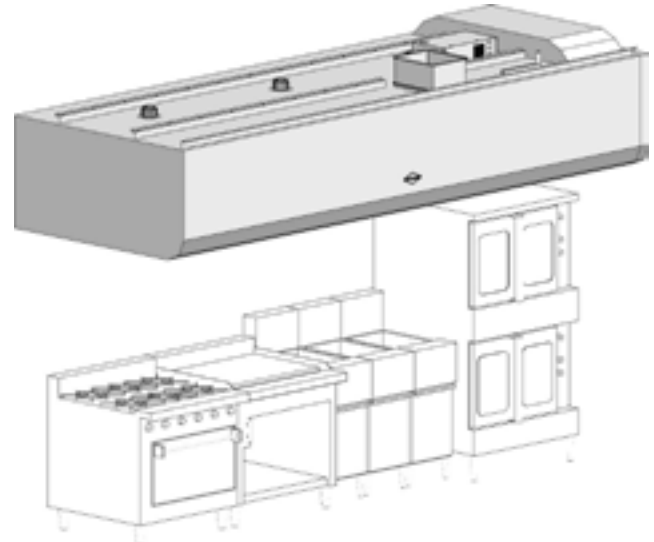

APPLICATION

Wall mounted canopy for use over all types of equipment; ovens, broilers, griddles, fryers, ranges, steam equipment, etc.

DESIGN FEATURES

- Demand Control Ready
- Clean-In-Place Technology
- Ultraviolet System
- Smoke and Odor Control

OPTIONAL EQUIPMENT

1. Cold Water Mist
2. Decorative Facings and Trim
3. AirVantage DCKV
4. Smoke Filter & Safety Media Bed Odor Control Module
5. Fire Extinguishing Systems
6. Utility Distribution Systems

when operated in accordance with the operation and maintenance guidelines. Each cell shall have 12 tungsten wires run perpendicular to the exhaust air flow which will ionize the air stream. Spike type systems shall not be accepted. The cell shall be positioned on slide tracks so it may be easily removed through a cell access door. For ease of handling, each individual cell shall weigh less than 45lbs. An electrical panel mounted in the unit shall contain the high voltage power pack assembly and safety disconnect switch for safe operation. The safety disconnect switch shall interface with the electrical panel access door such that when opened it will shut off service to the power pack(s) and ground them to drain the residual electrical charge from both the power pack(s) and ESP cell. The high voltage power pack(s) shall be self-limiting type and shall be self-contained. The unit shall contain wash manifold(s) on the top of the cell and the inlet side of the cell with fixed spray nozzles to wash the ESP



GAYLORD INDUSTRIES

10900 SW AVERY ST • TUALATIN, OREGON 97062 U.S.A.
PHONE: 800.547.9696 • FAX: 503.692.6048 • email: info@gaylordventilation.com
www.gaylordventilation.com

SMOKE CONTROL SECTION CONTINUED:

cell daily with detergent-injected hot water. Required wash pressure is 40 to 80 PSI at a minimum of 120°F and a maximum of 140°F. An electric booster heater will be supplied with the GPC-7000SPC control cabinet to increase this to 160°F to 180°F. The booster will require a 230 volt 3-phase 40 amp minimum connection and the electrical requirement varies on model selected. Maximum water flow rate for the ESP section is not to exceed 8 GPM. The ESP cell section shall have a 2" drain with a motorized ball valve that closes when the wash system is off to prevent air bypassing the grease extractors in the hood. This drain shall connect to an approved grease trap prior to entering the sewer system.

CONSTRUCTION: Each ventilator section shall include non-gasketed and non-removable full length access panels to ease inspection of extractors, secondary filters, UV lamps, plenum and fire extinguishing system. The ESP section shall be mounted, sealed and accessible from inside the hood's canopy by gasketed access panels with keyed lift and turn latches. The ventilator shall be of all stainless steel construction, not less than 18 gauge, type 300 series. All exposed surfaces shall be a number 4 finish. The use of aluminized steel or galvanized steel is not acceptable. Continuous front and rear mounting brackets shall be provided to facilitate mounting to the wall and hanging from the overhead building structure. Minimum ventilator length is 6' 1" and can be built in multiple sections for longer applications.

LIGHT FIXTURES: The ventilator shall be equipped with:

- Recessed LED 10 Watts/Ft. Min.

Canopy mounted LED light fixtures provide 50 foot candles at the cooking surface and shall be factory pre-wired to a single connection point. Ventilators built in multiple sections shall be furnished with coiled flex conduit for interconnecting sections.

ACCEPTANCE & APPROVALS: Each ventilator shall include a listed Demand Control Autostart, fan equipment interlock, complying with IMC (optional outside North America). Each ventilator shall include a built-in 1" air space at the rear that is Listed for reduced clearance to combustibles, and is NFPA-96 and IMC compliant when mounting against a combustible wall. Each ventilator shall be Listed to UL Standard 710 and 710C, ULC S646, UL 867 and NSF/ANSI 2, comply with all requirements of NFPA-96, IMC, UMC, BOCA, and SBCCI standards.

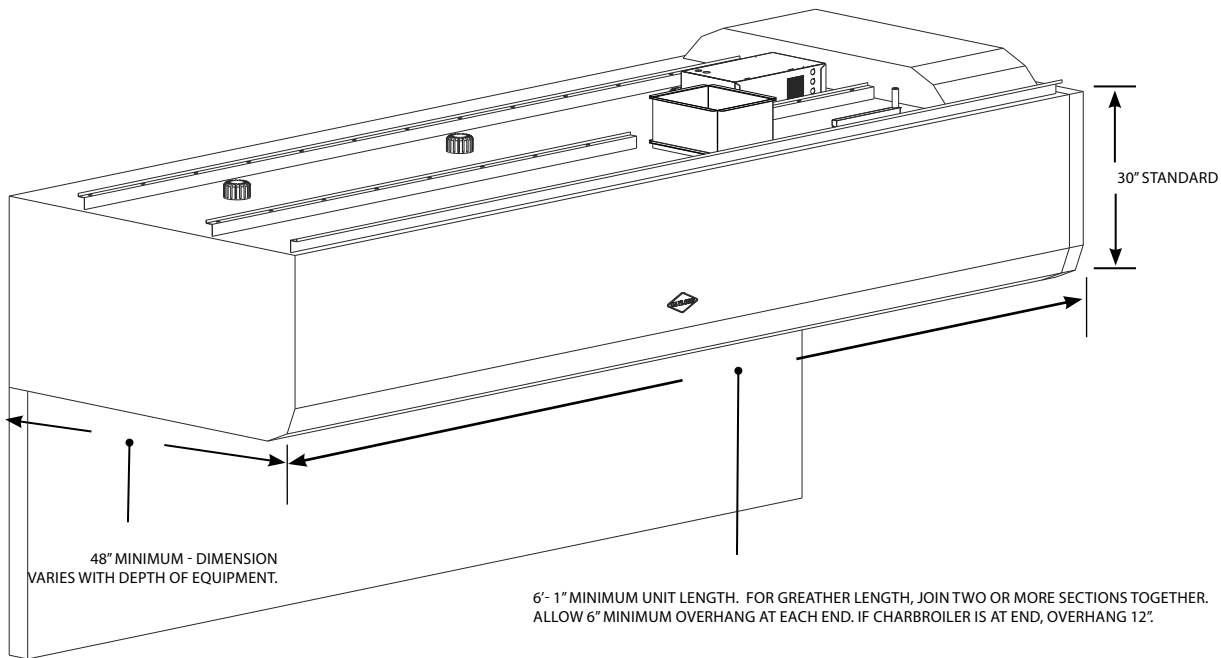

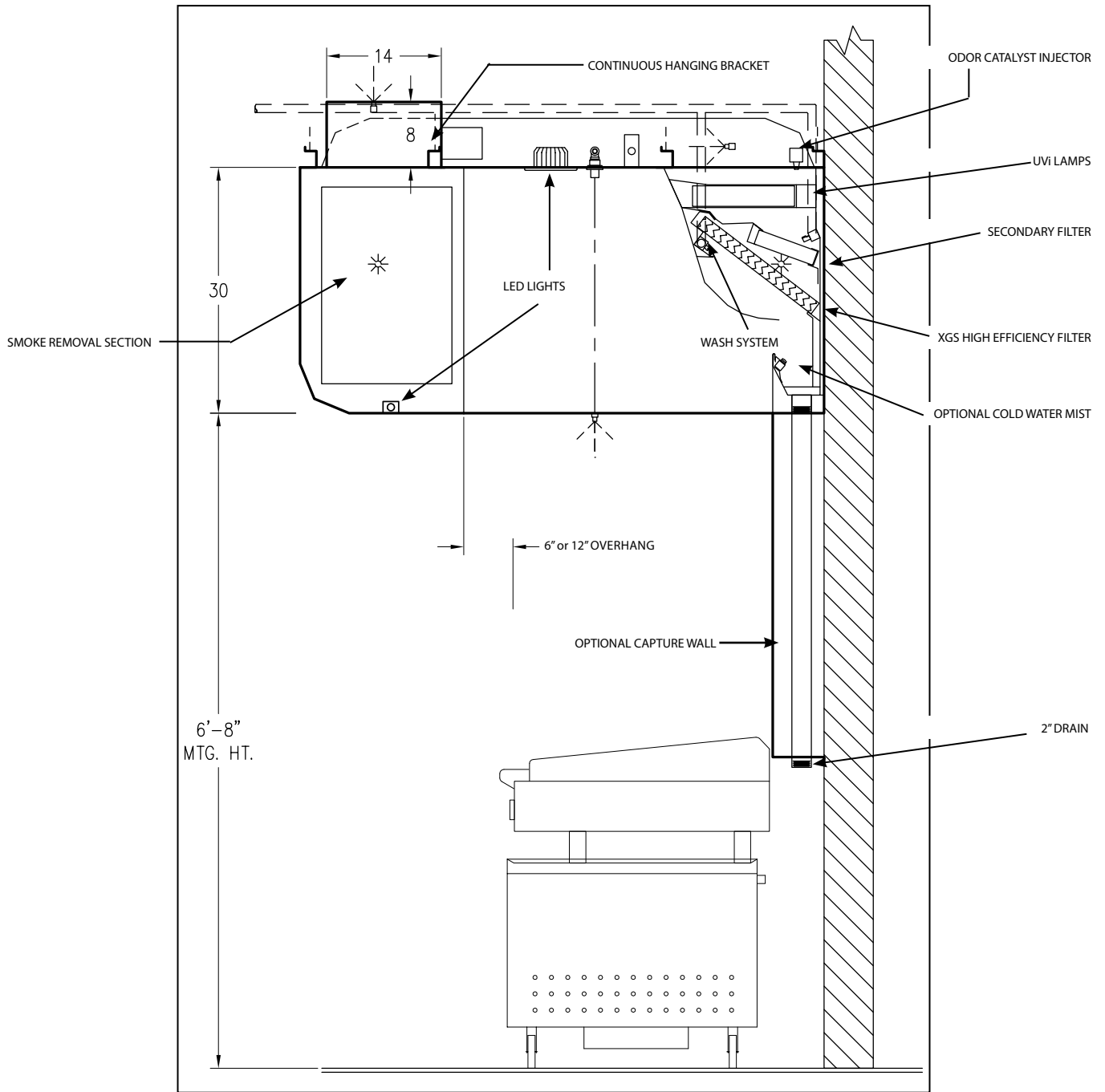

Mechanical Requirements

The amount of exhaust volume required is dependent upon the type of cooking equipment and the type and volume of cooking. Contact factory for exhaust volumes, duct sizes, and static pressures.

Electrical

Provide 120 volt 50/60Hz circuit to lights, 220/240 volt optional. Refer to Wash Control Cabinet for electrical requirements.

The manufacturer reserves the right to modify the materials and specifications resulting from a continuing program of product improvement or the availability of new materials

Ventilator Lengths

Minimum 6'-1" length and 14'-0" maximum single section length. For greater lengths, join two or more sections together. Check to ensure that there is adequate access into building and kitchen area. *Note: Ventilators manufactured outside North America; maximum unit length 10'-0".

Hanging Weight*

Ventilator Depth (inches)	72"	78"	84"	90"	96"	108"
Ventilator Wt/Linear Ft	lb/ft 160	170	180	190	200	210
Capture Wall	lb/ft 20	20	20	20	20	20

*Add 1000 lbs per duct collar