

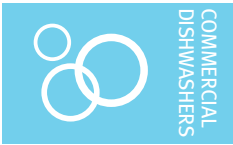

Project _____
 AIA # _____ SIS # _____
 Item # _____ Quantity _____ C.S.I. Section 114000



SL23 SIDE LOADING OPTION For CL Series



SPECIFIER STATEMENT

The mechanical SL23 Side Loader accessory is designed to provide automatic 90° indexing for corner loading. The SL23 is direction specific, adds 23" in length to the soiled side of the dishmachine and can accommodate all ware confined within a standard 20" x 20" foodservice rack. The SL23 is not compatible with Hobart Corner Scrapping units or CL-VL Ventless units.

MODELS

- SL23** Adds 23" to length of machine

STANDARD FEATURES

- + Automatically indexes rack at a 90° angle
- + Operates off the drive of the CL and requires no additional energy consumption
- + Easy to install
- + Stainless steel construction
- + Low maintenance
- + Easy to use
- + Saves valuable floor space
- + SL23 does not accept full size sheet pans; use model SL30 for full size sheet pans

Construction: Sump, back and end shields of formed 14-gauge stainless steel, heliarc-welded, with covered corners and all joints ground smooth and polished. Attached to dishmachine chamber with stainless steel bolts and reinforced with rigid stainless steel diagonal supports. Sump has 1½" drain connection and perforated stainless steel strainer cover over drain opening.

Conveyor: Two stainless steel rack slides welded to cross member support. Drive member is single stainless steel pawl, connected to dishmachine conveyor by a stainless steel rod. Rack drive pawl operates on two rollers, supported by two stainless steel rods and is beveled to permit rack to slide easily into side-loading extension.

Shipping Weight: Ships separately weighing approximately 100 lbs. Field mount standard.

Note: Racks must have center and side index strips.

WARNING: Electrical and grounding connections must comply with the applicable portions of the National Electrical Code and/or other local electrical codes.

Plumbing connections must comply with applicable sanitary, safety and plumbing codes.

CL SERIES – SL23 SIDE LOADING OPTION

Approved by _____ Date _____ Approved by _____ Date _____

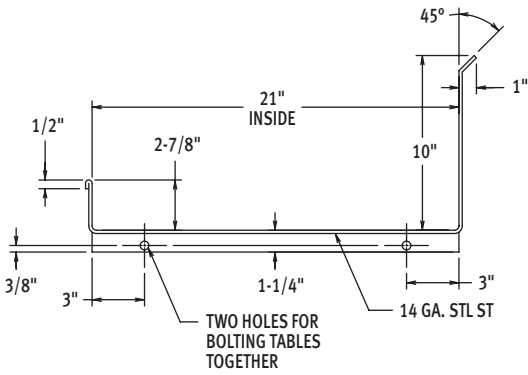

SECTION A-A
VIEW LOOKING TOWARD SL-23 TANK
THROUGH CUSTOMER'S TABLE

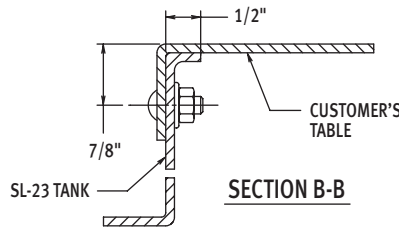

SECTION B-B

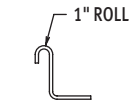

SECTION C-C

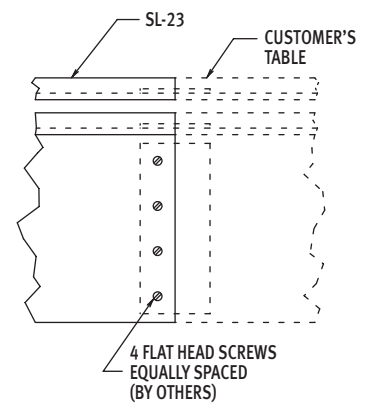

SECTION D-D

Note:

1. All dimensions taken from floor line may be increased approximately 3/4" or decreased 1/2". For dimensions not shown, see specification sheet for model specified.

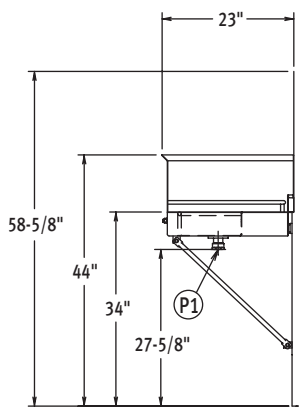
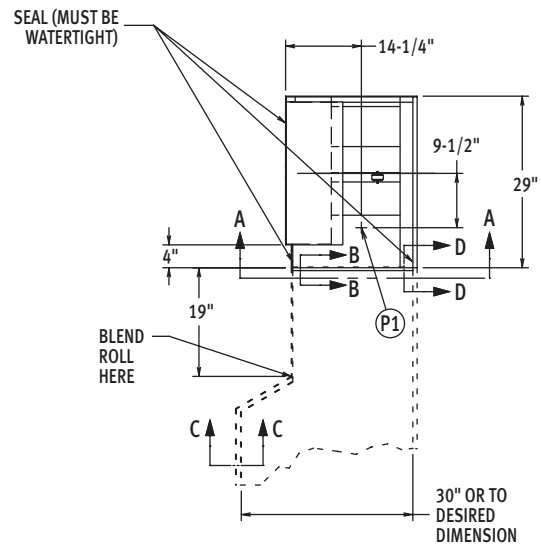
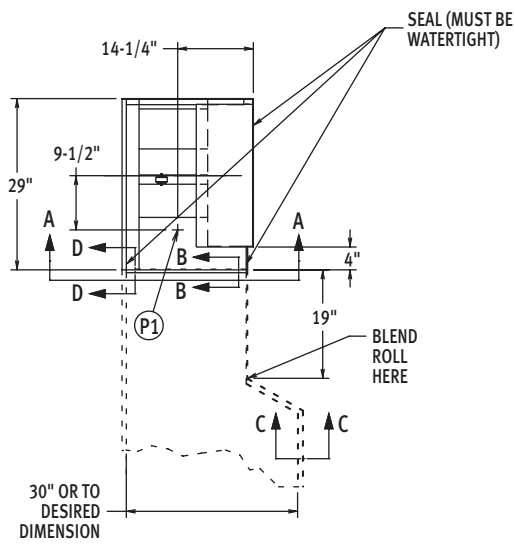

**SL23 Side Loader
Left to Right Operation**

LEGEND

Plumbing Connection	
P1	Drain connection: 1-1/2" FPT.

MODEL:
CL 23" SIDE LOADER
L-R OPERATION
D-936611
REV C

LEGEND

Plumbing Connection	
P1	Drain connection: 1-1/2" FPT.

MODEL:
CL 23" SIDE LOADER
R-L OPERATION
D-936610
REV C

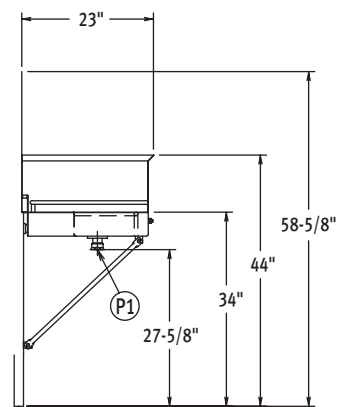

**SL23 Side Loader
Right to Left Operation**